

Features

- Ambient light illumination measurement reliable and accurate in both external and internal conditions
- The 4-20 mA loop output signal is supplied by the same power cable
- Easy to install and orientate.
- Luxmeter with different illumination range selectable in the same device



Applications

- Indoor buildings lighting Control.
- Blinds control.
- Supermarkets lighting control.

Description

The outdoor luxmeter LUX420S2 measures illuminance (lux) of ambient light and converts it into a signal current loop. The output signal of 4-20 mA of this illumination meter is provided by the same power supply cable, providing easy installation cabling.

It is based on a photo-sensor Yes, that offers a sensitivity close to visible light, and behavior estable.

The different measuring ranges are easily selected via microswitches.

Also offers high degree of protection for exterior and solid steel construction steel.

Outdoor Luxmeter Technical Specifications.

Parameters

Power supply	12- 30 Vdc (± 10%)
Output signal	4- 20 mA
Illuminance Range	Selectable range , 0-1000 lux, 0-2500 lux, 0-5000 lux, 0-10000 lux, 0-30000 lux, 0-50000 lux, 0-100000 lux
Linearity	<1%
Accuracy	<± 5% FS (0-1000 lux), <± 5% FS (0-2500 lux), <± 5% FS (0-5000 lux), <± 5% FS (0-10000 lux), <± 5% FS (0-30000 lux), <± 5% FS (0-50000 lux) , <± 5% FS (0-100000 lux)
Spectral Sensitivity	Max. at 570 nm
Degree of protection	IP67
Exterior material	Stainless Steel
Working temperature	-30° - +60°
Working humidity	30%-80% without condensation
Conexion	2 m. cable

Sensitivity

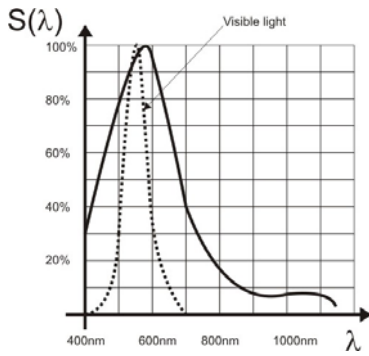

Output

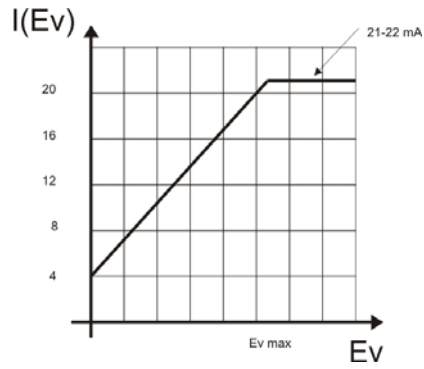

Dimensions

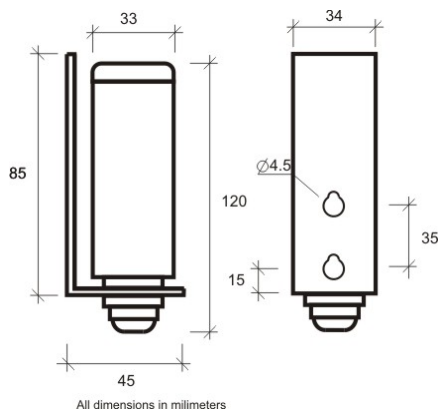

Conexion

